

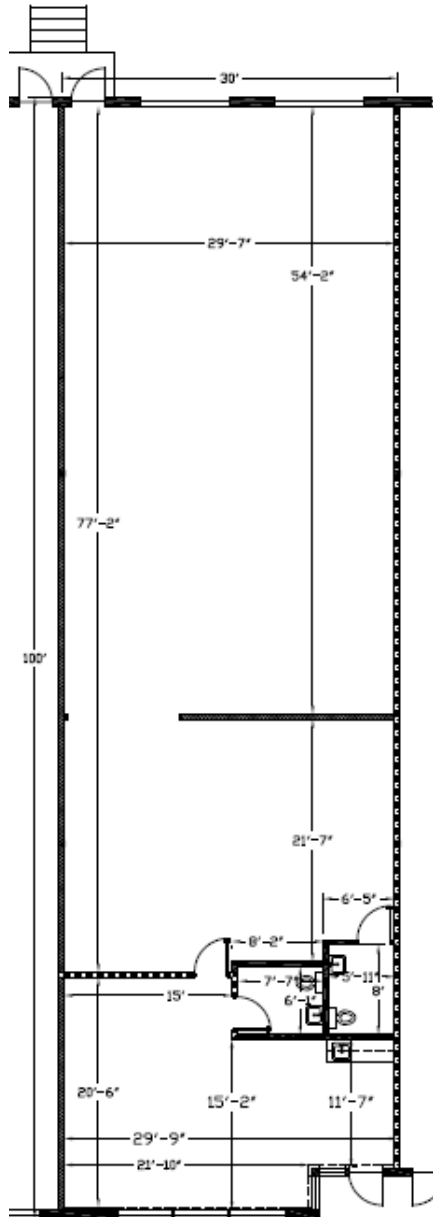

331 CORPORATE CIRCLE SUITE B

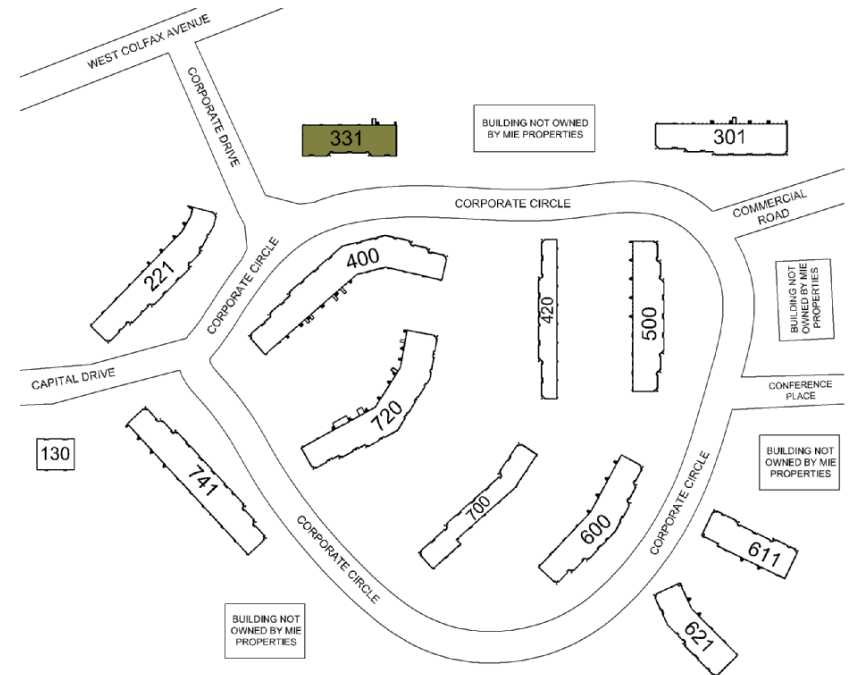

Unit s.f.	3,000 s.f.
Office s.f.	712 s.f.
Warehouse s.f.	2,288 s.f.
Clear Height	16'
Loading	Dock-high
Net Rent/s.f.	\$8.25 NNN
CAM/s.f.	\$3.85 (2011 estimated expenses)
Net Rent/mo.	\$2,063
Gross Rent/mo.	\$3,025
Additional Comments:	



MIE PROPERTIES, INC.
 420 Corporate Circle, Suite A
 Golden, Colorado 80401
 Telephone: (303) 278-7676 Fax: (303) 278-7666
www.miedenver.com